

benevelli
TRANSAXLES & POWER DRIVE UNITS
Made in Italy

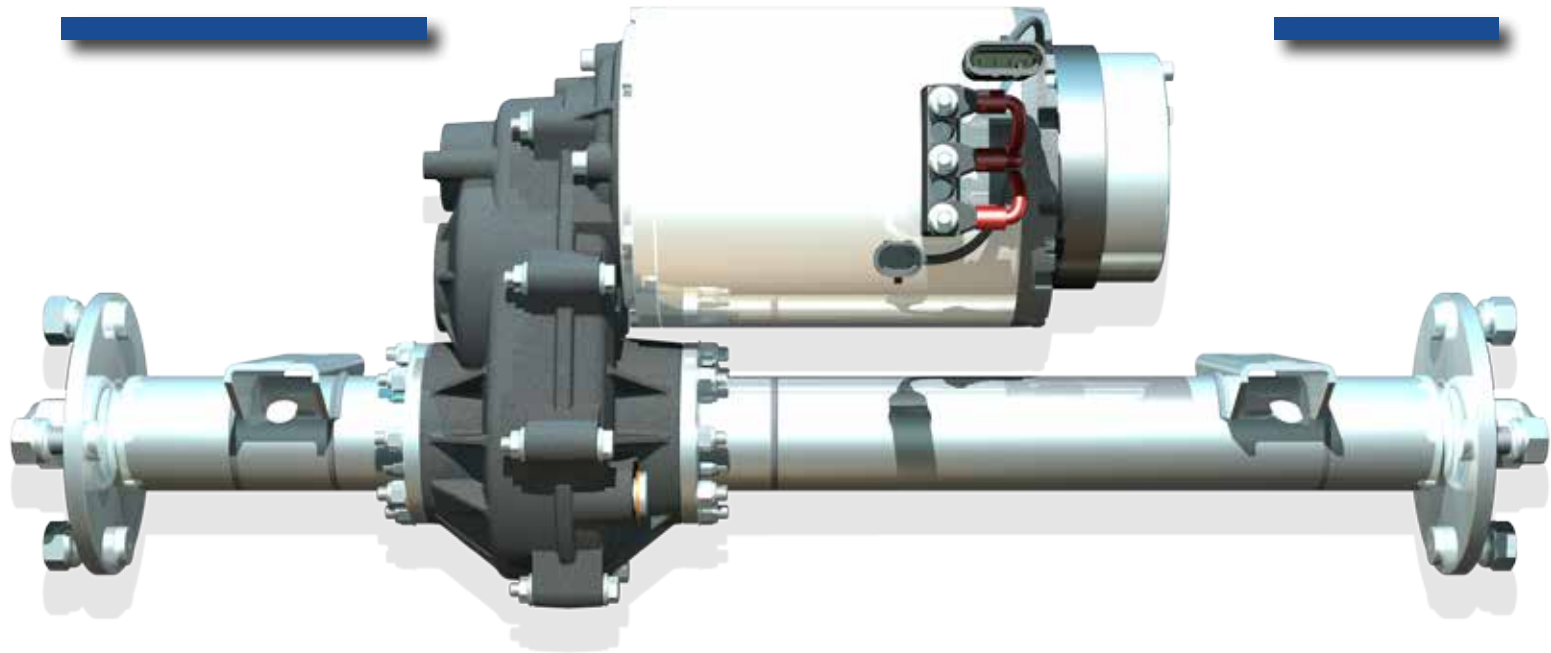

TXI SERIES

TRANSAXLES DRIVE UNIT

ALPATEK
BATTERY DRIVE SYSTEMS AND MOTORS

AC WHEEL HUBS VERSION

TX1 AC WHEEL HUBS VERSION

Asynchronous High Efficiency Motors

The TX1 Transaxle Drive System is a complete package comprised of a reduction/differential gear assembly, rigid drive axle, AC motor and an electromagnetic parking brake. Different gear ratios, trackwidth, wheel hubs and differential locking system are available for customization. The main features of our products are their extremely robust structure and high quality components for a heavy duty use, every product is designed and produce in our facility, for this reason we can guarantee a strong control over quality and repeatability.

Technical Specifications

Gear Ratios	1:06 1:09 1:11 1:13 1:16 1:22 1:24 1:32
Output Torque	400Nm (295ft.lbs) Maximum
Input Speed	7200Rpm Maximum
Static Load Rating	400Kg (880lb)
Lubrication	Oil SAE80W90 GL3 0,25Litres (0,44Pintes)
Trackwidth	From 400mm (16") up to 1150mm (45")
Fixing	Mounting Brackets
Cast Housing	Aluminium/Silicon Alloy
Gears Finishing	Involute Grinding Profile
Differential Type	Bevel Gear
Efficiency	95%
Motor Type	Asynchronous
Motor Rated Power	From 0,8kW up to 1,5kW
Motor Rated Voltage	From 24V up to 48V
Motor Insulation	Class F 155°C (311°F)
Braking System	Electromagnetic Brake
Braking Torque	From 4Nm up to 20Nm



TXI AC WHEEL HUBS VERSION

Gears Finishing

Hardened alloy steel gears with involute grinding profile ensure maximum efficiency and low constant noise level

AC Motor

High Efficiency Aluminium built-in motor designed for traction use. It includes temperature sensor and speed encoder.

EM Brake

Available with several braking torques, it slow and stop trans-axle motion. Hand release available on demand

Mounting Position

Six (6) standard mounting position (tilt on Z axis from 0° to 180°) gives to trans-axle several installation possibilities

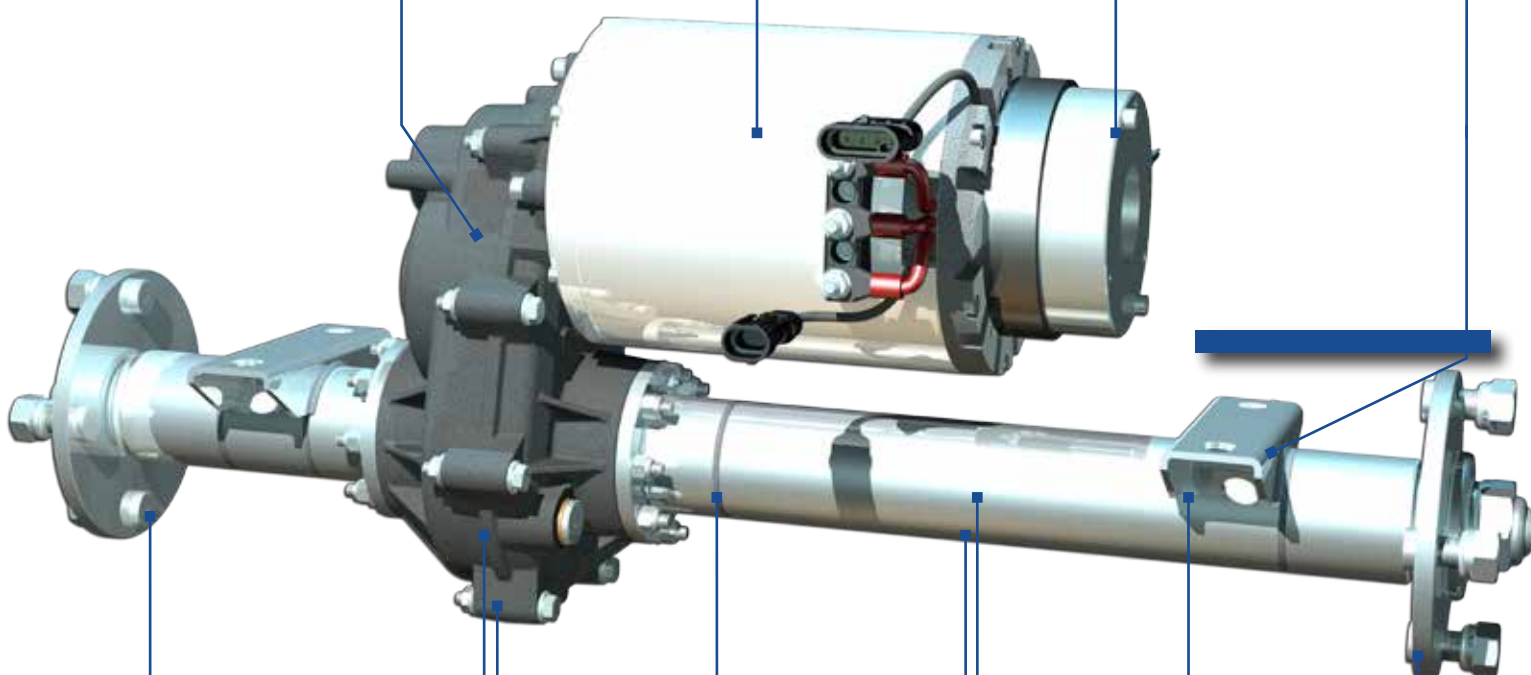

Wheel Fixing

Twenty (20) different wheel hub models available (interchangeable), with or without wheel studs and nuts

Weldings

Welding operations are performed by robots ensuring the highest safety criteria (TÜV certified EN ISO 15614:2012)

Lubrication

All our products are supplied "ready to use" with adequate quantity and quality lubricating oil

Rigid Axle

Drawn tubes 51mm diam. & 7,5mm thickness are heavily installed with built-in studs on gearbox housing

Chassis Fixation

Several standard mounting centres available, other mounting options can be developed on demand

Gearbox Casting

Compact and rugged Aluminium alloy gear housing minimizes weights adding strength thanks to the new "Heavy Duty" design

Finishing

All metallic parts are subjected to long life galvanizing treatment (zinc coating) to withstand the corrosive agents aggression

Track-Width

Five Hundred (500) adjustable standard track-width available on stock from 400mm up to 1150mm (flange to flange)

Designed & Manufactured in Italy

our products are sold in 40 countries across 5 continents

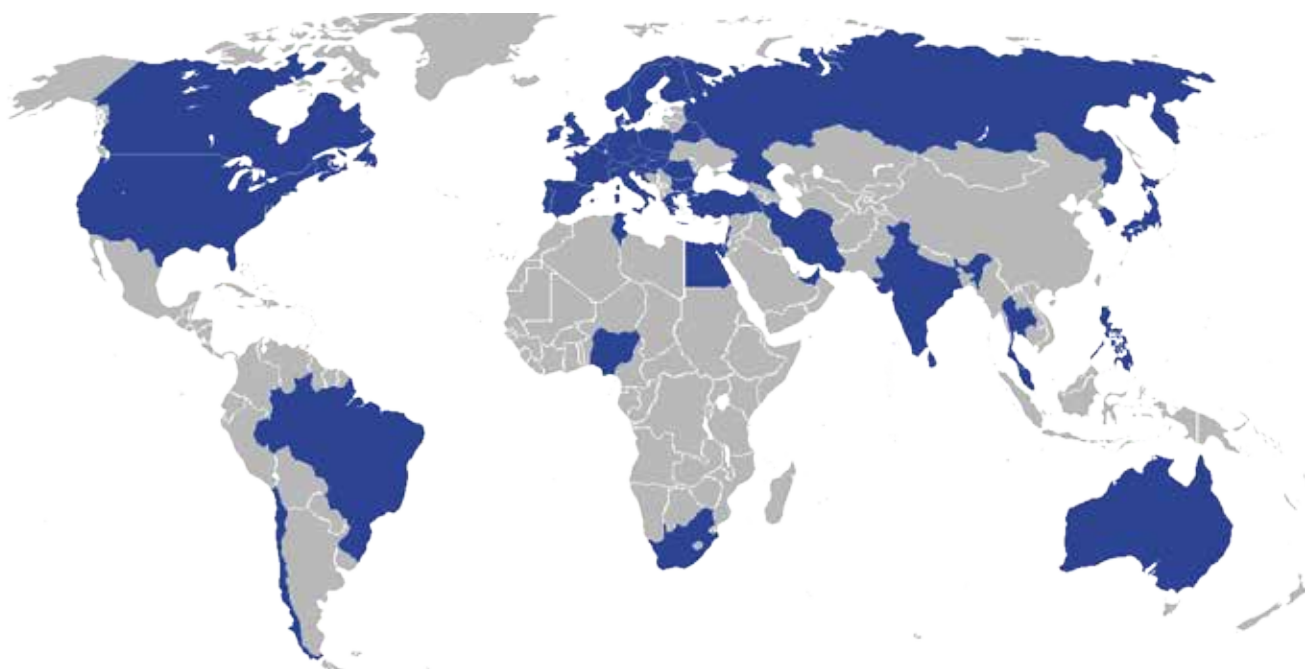

Abu Dabhi
 Austria
 Australia
 Belarus
 Belgium
 Brazil
 Bulgaria
 Canada
 Chile
 Croatia
 Czech Republic

Denmark
 Dubai
 Finland
 France
 Germany
 Hungary
 India
 Iran
 Ireland
 Israel
 Italy

Japan
 Lebanon
 The Netherlands
 Nigeria
 Norway
 Philippines
 Poland
 Portugal
 Romania
 Russia
 Singapore

Slovenia
 South Africa
 South Korea
 Spain
 Sweden
 Switzerland
 Thailand
 Tunisia
 Turkey
 United Kingdom
 U.S.A.

