

benevelli

TRANSAXLES & POWER DRIVE UNITS
Made In Italy

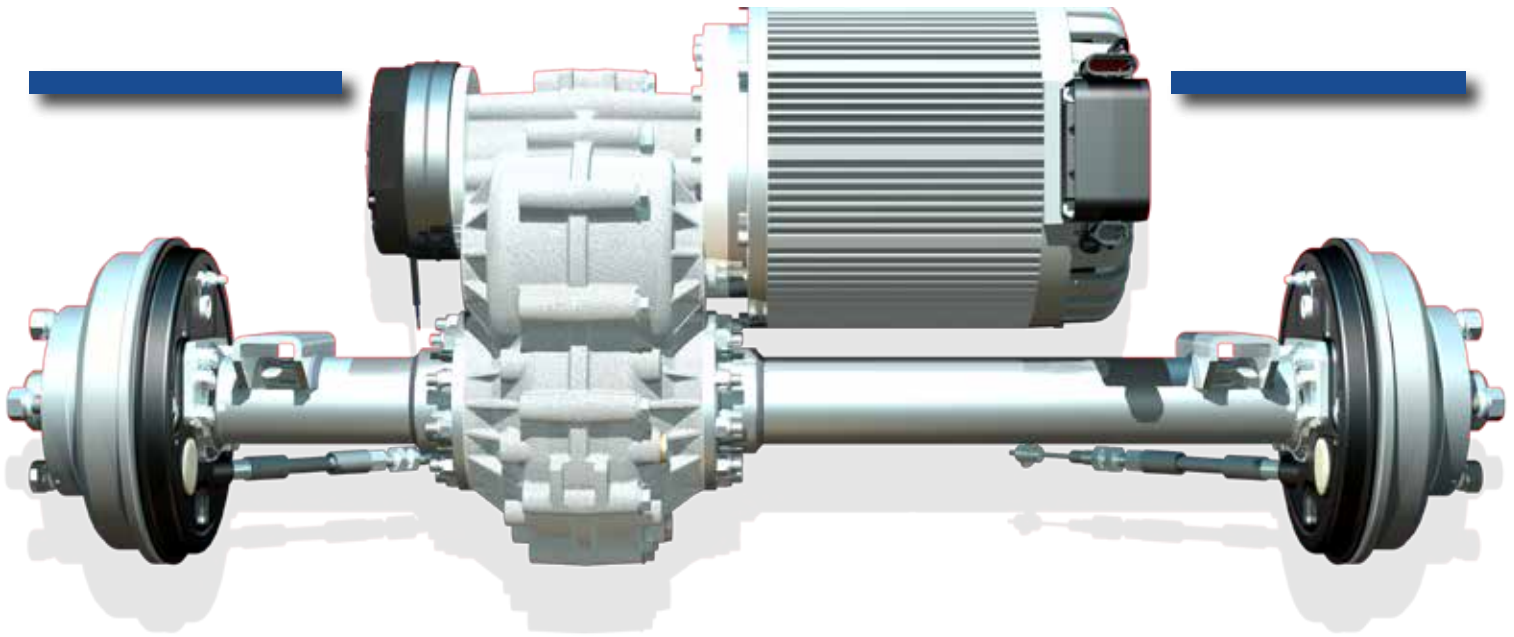

TX2 SERIES

TRANSAXLES DRIVE UNIT

ALPATEK

BATTERY DRIVE SYSTEMS AND MOTORS

AC DRUM BRAKES VERSION

TX2 AC DRUM BRAKES VERSION

Asynchronous High Efficiency Motors

The TX2 Transaxle Drive System is a complete package comprised of a reduction/differential gear assembly, rigid drive axle, AC motor and an electromagnetic parking brake. Different gear ratios, track-width, wheel hubs, drum brakes are available for customization. The main features of our products are their extremely robust structure and high quality components for an heavy duty use, every product is designed and produced in our Italian facility, for this reason we can guarantee a strong control over quality and repeatability.

Technical Specifications

Gear Ratios	1:05 1:07 1:10 1:13 1:16 1:22 1:28 1:35 1:43 1:56
Output Torque	1400Nm (1032ft.lbs) Maximum
Input Speed	7200Rpm Maximum
Static Load Rating	1400Kg (3086lb)
Lubrication	Oil SAE80W90 GL3 0,5Litres (1.05Pintes)
Trackwidth	From 600mm (23.5") up to 2000mm (78.5")
Braking System	Hydraulic, Mechanical and Electromagnetic
Braking Torque Hyd/Mec.	1200Nm
Braking Torque Elect.	From 20Nm up to 50Nm
Fixing	Mounting Brackets
Cast Housing	Aluminium/Silicon Alloy
Gears Finishing	Involute Grinding Profile
Differential Type	Bevel Gear
Efficiency	95%
Motor Type	Asynchronous
Motor Rated Power	From 2.0kW up to 10.0kW
Motor Rated Voltage	From 24V up to 80V
Motor Insulation	Class F 155°C (311°F)

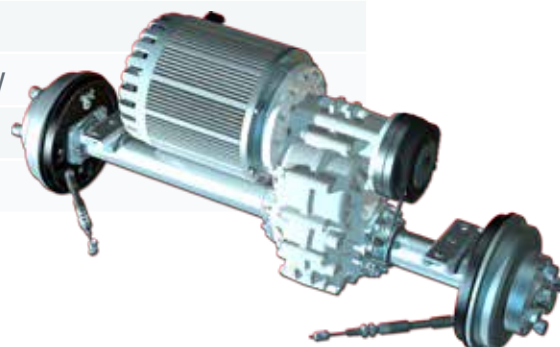

TX2 AC DRUM BRAKES VERSION

EM Brake

Available with several braking torques, it slow and stop trans-axle motion. Compact size thanks to its position (opposite side to the motor). Hand release available

Gears Finishing

Hardened alloy steel gears with involute grinding profile ensure maximum efficiency and low constant noise level

AC Motor

High Efficiency Aluminium built-in motor designed for traction use. It includes temperature sensor and speed encoder

Mounting Position

Seven (7) standard mounting position (tilt on Z axis from 0° to 180°) gives to trans-axle several installation possibilities

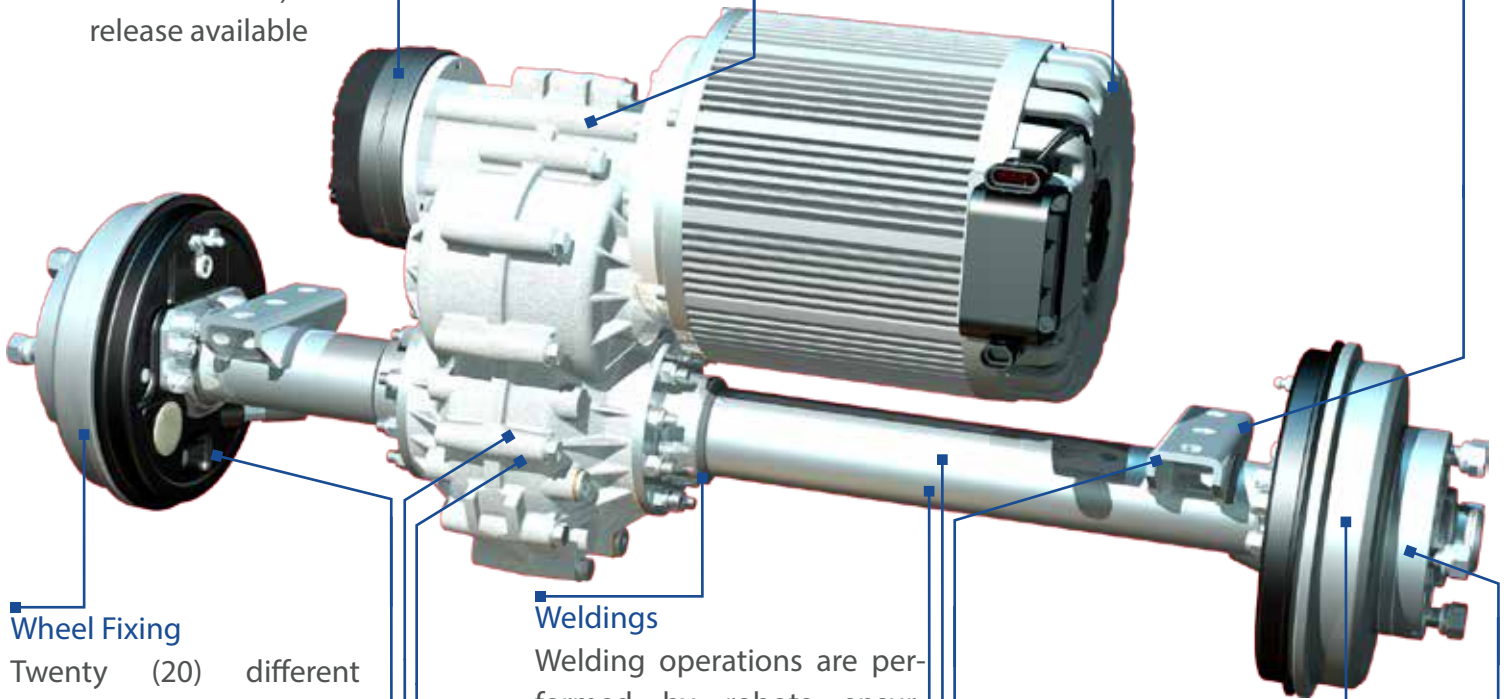

Wheel Fixing

Twenty (20) different wheel hub models available (interchangeable), with or without wheel studs and nuts

Weldings

Welding operations are performed by robots ensuring the highest safety criteria (TÜV certified EN ISO 15614:2012)

Drum Brakes

Mechanical/Hydraulic operated drum braking system (service brake) specifically designed for electric powered light vehicles

Finishing

All metallic parts are subjected to long life galvanizing treatment (zinc coating) to withstand the corrosive agents aggression

Lubrication

All our products are supplied "ready to use" with adequate quantity and quality lubricating oil

Rigid Axle

Drawn tubes 58mm diam. & 8mm thickness are heavily installed with built-in studs on gearbox housing

Gearbox Casting

Aluminium alloy gear housing minimizes weights adding strength thanks to the Heavy Duty design

Chassis Fixation

Several standard mounting centres available, other mounting options can be developed on demand

Wheel Bearings

Angular contact double row bearings & splined driveshafts allow use of transaxles in intensive conditions



Track-Width

Four Hundred (400) adjustable standard track-width available on stock from 600mm up to 2000mm (flange to flange)

Designed & Manufactured in Italy

our products are sold in 40 countries across 5 continents

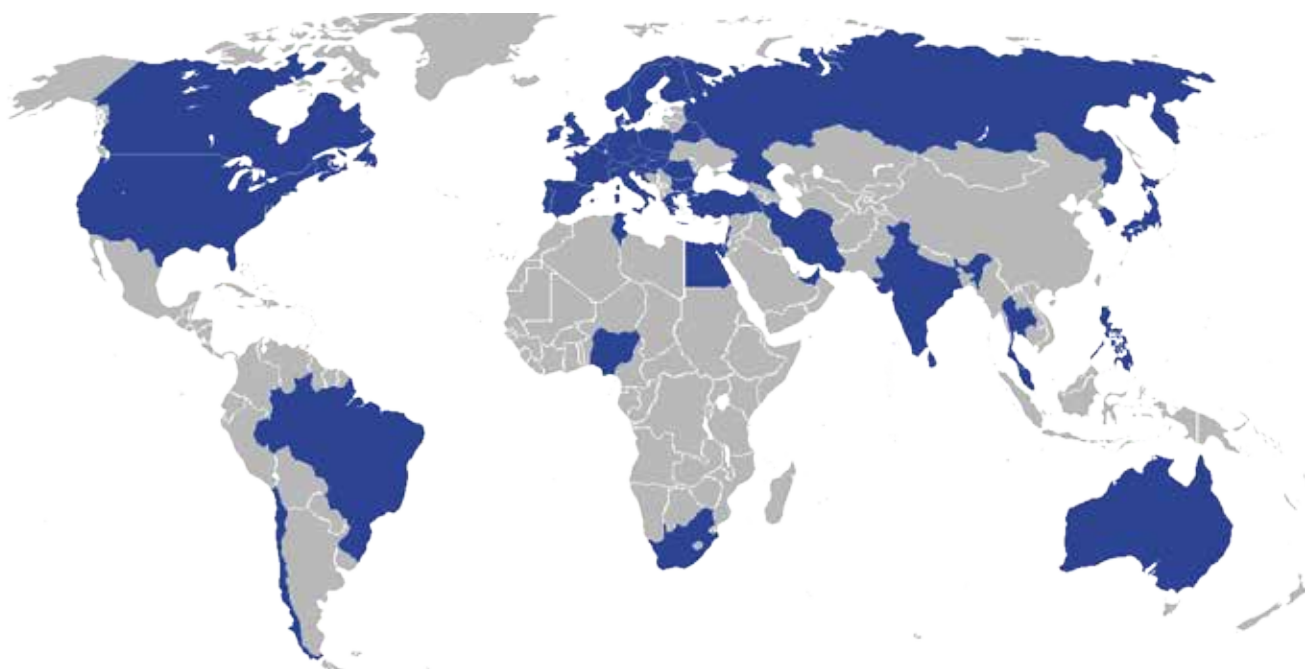

Abu Dabhi
 Austria
 Australia
 Belarus
 Belgium
 Brazil
 Bulgaria
 Canada
 Chile
 Croatia
 Czech Republic

Denmark
 Dubai
 Finland
 France
 Germany
 Hungary
 India
 Iran
 Ireland
 Israel
 Italy

Japan
 Lebanon
 The Netherlands
 Nigeria
 Norway
 Philippines
 Poland
 Portugal
 Romania
 Russia
 Singapore

Slovenia
 South Africa
 South Korea
 Spain
 Sweden
 Switzerland
 Thailand
 Tunisia
 Turkey
 United Kingdom
 U.S.A.

