

AC Induction Motor Controller



DATASHEET

(Rev. 1.1: January 2014)



Model
AC-L1

SME inverters provide advanced control of AC induction motors for traction or pump functions of any electrical vehicle working with speed or torque control algorithms.

SmartMotion is an integrated controller which can manage multi-function and fully configurable I/O pins for any I/O functions like digital and analogue inputs and digital and analogue outputs, capable of driving fans, relays' and hydraulic valves' coils, contactors, negative brakes and many others inductive/resistive loads.

It is fully suitable for counterbalanced and warehouse trucks, all heavy-duty applications as Tow Tractors, Cleaning machines or Air Platform, any kind of passengers vehicles or utility vehicles as Electric scooter or Golf or City Cars.

Main features

- AC motor control features:
 - ✓ Indirect Field Oriented Control (IFOC) with unsurpassed dynamic and performance in full speed range by decoupling and regulating flux and torque vectors of stator current components
 - ✓ advanced Space Vector Modulation (SVM) technique for high system efficiency reducing motor harmonics and losses
 - ✓ accurate Rotor Flux Model and Fully Developed Field Weakening technique for high motor efficiency and dynamic across full speed range
 - ✓ optimization of stator losses is achieved through advanced management of rotor flux on all load conditions
 - ✓ motor model fully compatible with IEEE Standard in order to get the parameters of motor's equivalent circuit from no-load and blocked rotor tests; it can work with all AC motors of all manufactures
- Fully configurable through supplied GUI, which reduces abruptly the time to market start-up of the system
- Standard and same firmware for all inverter series (easily extendable to future models)
- Robust, safe and self diagnostic (both for hardware and software fault conditions)
- CAN Open and serial interfaces
- Powerful logging of all sensible working variables
- Full product tracking

Technical specification for ACL1 Smartmotion inverter series

Electrical and Power

Maximum RMS inverter current (2')	ACL1 36-48V	625Arms 750Arms
	ACL1 72-80V	600Arms 750Arms
PWM operating frequency		9KHz
Efficiency		> 95%
Protection level		IP65
Mechanical size		210 x 190 x 91 [mm]
Weight		3,8 kg
Vibration		5g, 10÷500Hz, 3 axes
Working temperature range		-30 / +40°C
Storage temperature range		-40 / +50°C
Maximum case temperature		100°C

Regulatory compliance

- EN1175 for safety
- EN12895 for Electromagnetic compatibility
- UL Recognized Component; meets UL583 dielectric test

The vehicle OEM takes full responsibility of the regulatory compliance of the vehicle system with the controller installed.

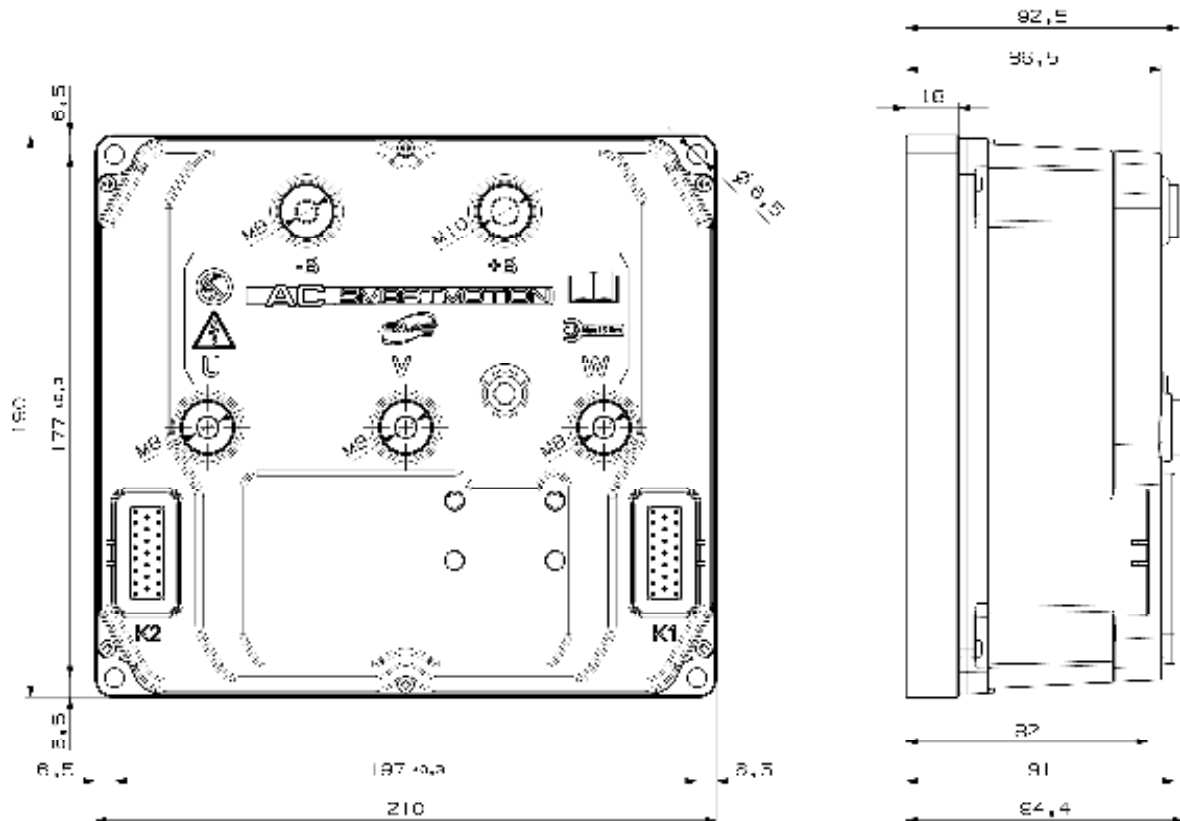



Controller Inputs and Outputs

Digital Inputs	19
Analogue Inputs	8
Outputs (inductive or resistive load)	2 ON/OFF 3 PWM
Motor speed sensor inputs	2 A + B channels

Interfaces

CAN Protocol	CANOpen Physical layer uses ISO11898-2 Baud rates: 1Mbps, 800kbps, 500kbps, 250kbps, 125kbps
Serial communication	RS-232
LIN bus	Yes

Advanced functionalities

“Standalone” Firmware Family

- Flexible assignment of I/O in order to couple them to any provided functions
- Transfer characteristics of all analog inputs can be set and modified graphically
- Quick setting and support of all kind of throttles in the market
- All outputs can be fully configured (relays, fans, negative brake,..) in relation to the control variable (input pin, temperature of motors or inverters, working conditions)
- Three different operative modes can be configured in all their settings by the customer and easily selected while the system is working
- AC motor control:
 - ✓ selection between Torque Control and Speed Control is easy and quick; system grants good feeling in both through a smooth, dynamic and precise response
 - ✓ auto setup of PI control parameters based on actual motor characteristic permits the safe and immediate tuning of motor's behavior
 - ✓ current and torque limits at different speed can be safely set by the customer, in a full graphical way, limited only by inverter's max ratings
 - ✓ speed/torque rates in all working condition are fully configurable
 - ✓ speed/torque self-limitations are fully configurable, depending on temperature or digital/analogue inputs
- Powerful and precise hill-hold function can be configured and activated in different conditions: on switch activation, on pedal brake activation, always active or always off
- Battery current estimation is provided without any further current probe;
- Advanced State of Charge algorithm which combines both Columbian current integration and Open Circuit Voltage characteristics;
- Complete diagnosis of thermal history and of faults history in order to improve inverter's reliability and help the customer to develop the right power dimensioning;



- Complete data logger of all working variables;
- Firmware and parameters upgradable on field;
- Main working parameters, which are fully configurable by GUI, can be shown by the SME Compact or Mini Displays;
- Troubleshooting and diagnostics are made easy.

Advanced functionalities

“TAU System” Firmware Family

- Capability of building complex distributed control systems over CANopen data bus;
- Additional TAU nodes can be easily added to the CAN bus increasing system capabilities, functions and power;
- Building of safety and robust networks is possible through quick and easy parameters configuration;
- Different controllers can be configured to interact with other in order to implement various functions and behaviors;
- System faults can be managed from single nodes with high flexibility to achieve the desired behavior in all conditions;
- System mains can be managed from each node by itself or with the help of other nodes;
- Battery state of charge can be estimated with best accuracy taking into account the contribution of every node;
- Most of Li-Ion battery management systems (BMS) are supported and can be simply connected to system CAN bus;
- Most kinds of CAN displays can be supported through fully-configurable PDOs;
- *SME EVC-1* hydraulic valves controller can be easily connected and configured in system where you need to control proportional or on/off hydraulic electro-valves.