

***benevelli***

TRANSAXLES & POWER DRIVE UNITS  
Made in Italy

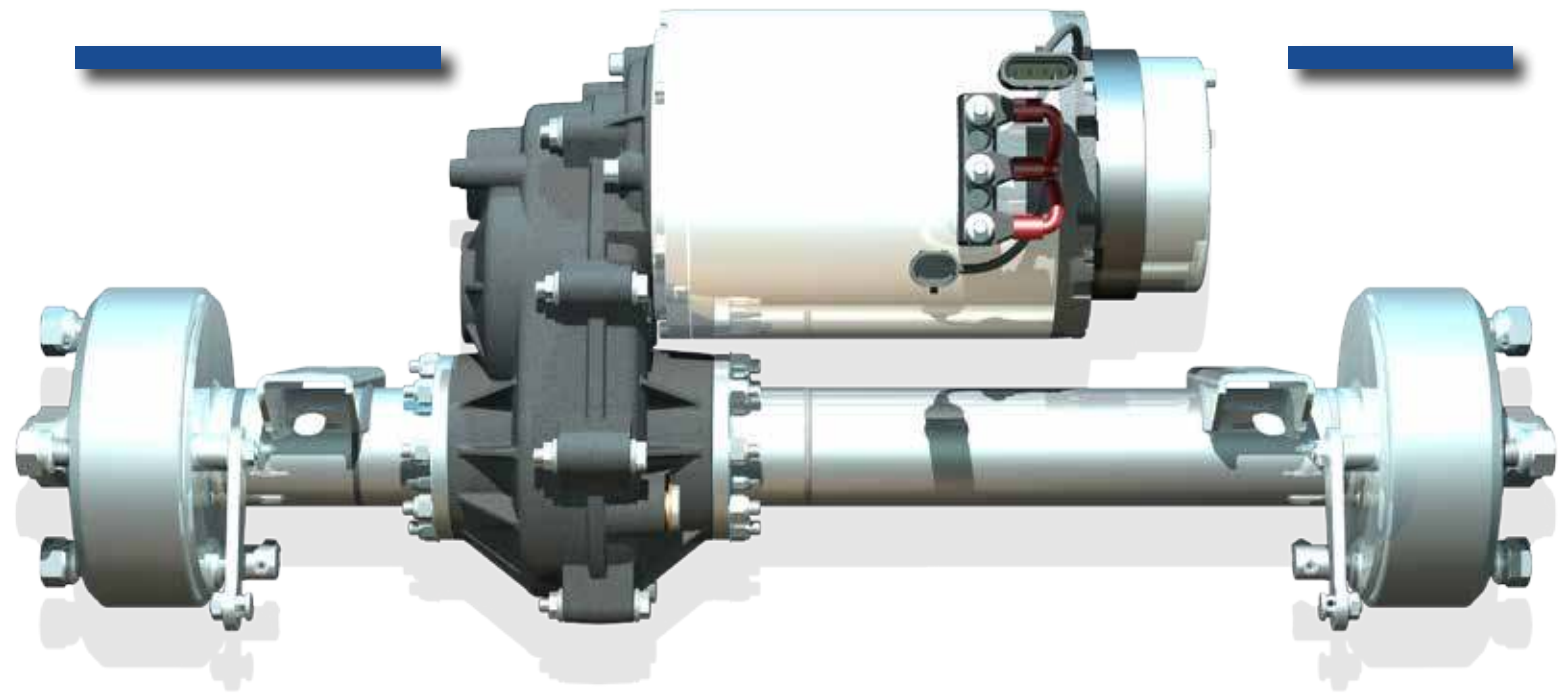

# TXI<sup>plus</sup> SERIES

TRANSAXLES DRIVE UNIT

EXCLUSIEVE DISTRIBUTIE VOOR DE BENELUX:

**ALPATEK**

BATTERY DRIVE SYSTEMS AND MOTORS

AC DRUM BRAKES VERSION

## Asynchronous High Efficiency Motors

The TX1 Transaxle Drive System is a complete package comprised of a reduction/differential gear assembly, rigid drive axle, AC motor and an electromagnetic parking brake. Different gear ratios, trackwidth, wheel hubs and differential locking system are available for customization. The main features of our products are their extremely robust structure and high quality components for a heavy duty use, every product is designed and produce in our facility, for this reason we can guarantee a strong control over quality and repeatability.

## Technical Specifications

Gear Ratios	1:06 1:09 1:11 1:13 1:16 1:22 1:24 1:32
Output Torque	450Nm (332ft.lbs) Maximum
Input Speed	7200Rpm Maximum
Static Load Rating	500Kg (1100lb)
Lubrication	Oil SAE80W90 GL3 0,25Litres (0,44Pintes)
Trackwidth	From 400mm (16") up to 1150mm (45")
Braking System	Mechanical and Electromagnetic
Braking Torque Mechanical	500Nm
Braking Torque Electromag.	From 4Nm up to 20Nm
Fixing	Mounting Brackets
Cast Housing	Aluminium/Silicon Alloy
Gears Finishing	Involute Grinding Profile
Differential Type	Bevel Gear
Efficiency	95%
Motor Type	Asynchronous
Motor Rated Power	From 0,8kW up to 1,5kW
Motor Rated Voltage	From 24V up to 48V
Motor Insulation	Class F 155°C (311°F)

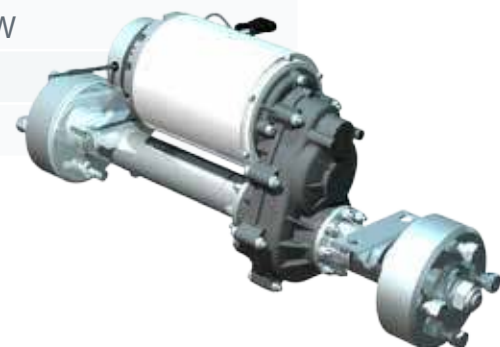

# TXI AC DRUM BRAKES VERSION

## Gears Finishing

Hardened alloy steel gears with involute grinding profile ensure maximum efficiency and low constant noise level

## AC Motor

High Efficiency Aluminium built-in motor designed for traction use. It includes temperature sensor and speed encoder.

## EM Brake

Available with several braking torques, it slow and stop trans-axle motion. Hand release available on demand

## Mounting Position

Six (6) standard mounting position (tilt on Z axis from 0° to 180°) gives to trans-axle several installation possibilities

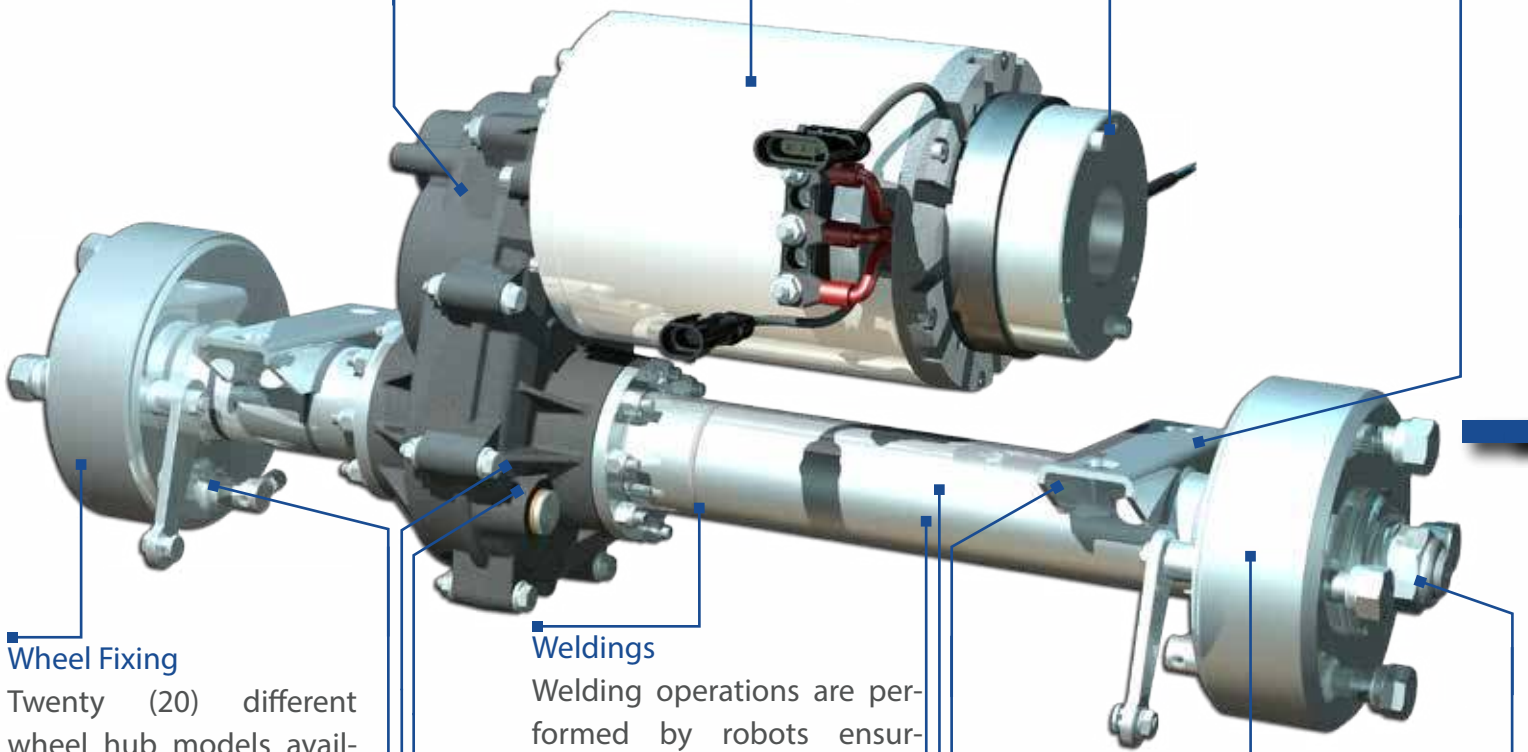

## Wheel Fixing

Twenty (20) different wheel hub models available (interchangeable), with or without wheel studs and nuts

## Weldings

Welding operations are performed by robots ensuring the highest safety criteria (TÜV certified EN ISO 15614:2012)

## Drum Brakes

Mechanically operated drum braking system (service brake) specifically designed for electric powered light vehicles

## Finishing

All metallic parts are subjected to long life galvanizing treatment (zinc coating) to withstand the corrosive agents aggression

## Lubrication

All our products are supplied "ready to use" with adequate quantity and quality lubricating oil

## Rigid Axle

Drawn tubes 51mm diam. & 7,5mm thickness are heavily installed with built-in studs on gearbox housing

## Gearbox Casting

Aluminium alloy gear housing minimizes weights adding strength thanks to the new "Heavy Duty" design

## Chassis Fixation

Several standard mounting centres available, other mounting options can be developed on demand

## Wheel Bearings

Angular contact double row bearings & splined driveshafts allow use of transaxles in intensive conditions



## Track-Width

Five Hundred (500) adjustable standard track-width available on stock from 400mm up to 1150mm (flange to flange)

Designed & Manufactured in Italy

our products are sold in 40 countries across 5 continents

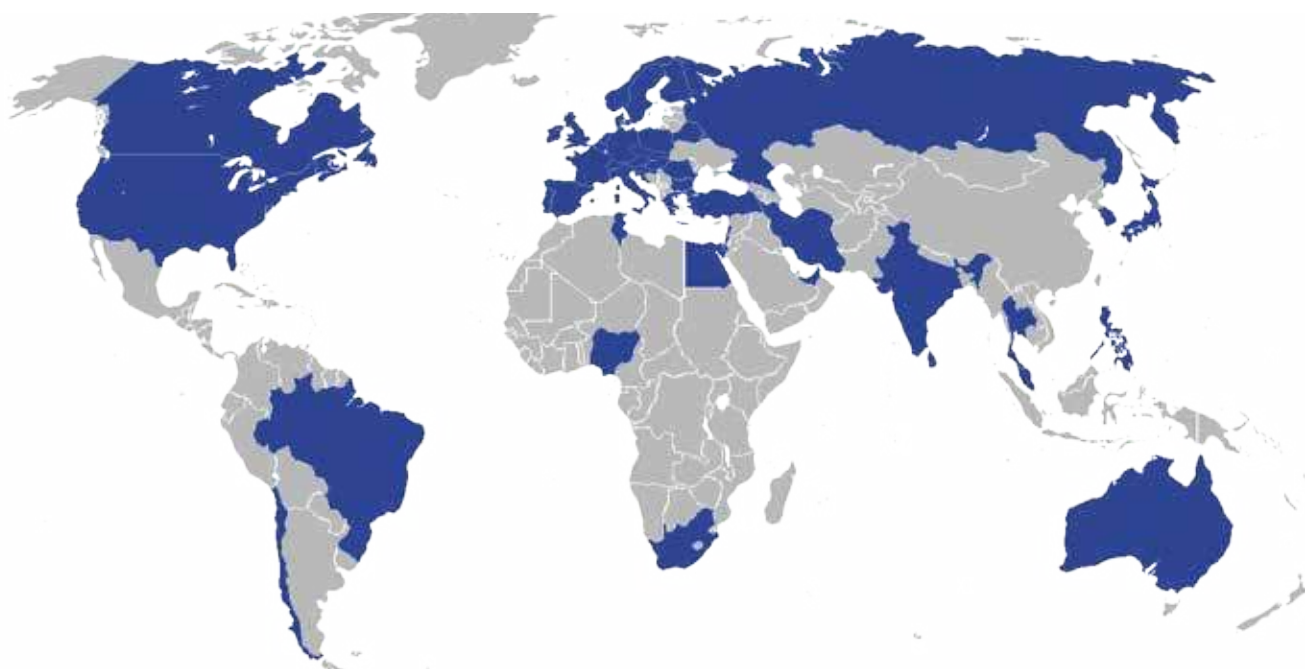

Abu Dabhi  
 Austria  
 Australia  
 Belarus  
 Belgium  
 Brazil  
 Bulgaria  
 Canada  
 Chile  
 Croatia  
 Czech Republic

Denmark  
 Dubai  
 Finland  
 France  
 Germany  
 Hungary  
 India  
 Iran  
 Ireland  
 Israel  
 Italy

Japan  
 Lebanon  
 The Netherlands  
 Nigeria  
 Norway  
 Philippines  
 Poland  
 Portugal  
 Romania  
 Russia  
 Singapore

Slovenia  
 South Africa  
 South Korea  
 Spain  
 Sweden  
 Switzerland  
 Thailand  
 Tunisia  
 Turkey  
 United Kingdom  
 U.S.A.

EXCLUSIEVE DISTRIBUTIE VOOR DE BENELUX:

