

**QUICK SELECTION / Selezione veloce**

input speed ( $n_1$ ) = 1400 min<sup>-1</sup>

Output Speed $n_2$ [min <sup>-1</sup> ]	Ratio $i$	Motor power $P_{1M}$ [kW]	Output torque $M_{2M}$ [Nm]	Service factor f.s.	Nominal power $P_{1R}$ [kW]	Nominal torque $M_{2R}$ [Nm]	Available B5 motor flanges					Available B14 motor flanges				Output Shaft 	Ratios code
							-C	-D	-E	-F	-G	-R	-T	-U	-V		
							71	80	90	100* 112	132*	80	90	100 112	132		
388	3.61	4	93	1.6	6.3	150	B									3018	01
331	4.23	4	108	1.6	6.1	170	B									3016	02
279	5.01	4	129	1.6	6.1	200	B									3014	03
231	6.07	4	156	1.6	6.3	250	B									3012	04
206	6.81	4	175	1.6	6.2	277	B									2018	05
176	7.96	4	204	1.5	5.8	300	B									2016	06
148	9.45	4	242	1.3	4.9	304	B									2014	07
122	11.43	4	293	1.0	4.0	300	B									2012	08
99	14.21	3	274	1.0	2.8	265	B									2010	09
84	16.62	3	321	0.9	2.8	304	B									1314	10
70	20.10	2.2	286	1.0	2.3	300	B									1312	11
56	24.98	1.85	302	0.9	1.6	265	B									1310	12
47.6	29.41	1.5	288	1.1	1.6	304	B									814	13
39.3	35.58	1.5	349	0.9	1.3	300	B									812	14
34.6	40.50	1.1	290	1.0	1.1	290	B									614	15
31.7	44.23	1.1	316	0.8	0.92	265	B									810	16
28.6	49.00	0.75	240	1.2	0.93	300	B									612	17
23.0	60.90	0.75	299	0.9	0.66	265	B									610	18

The dynamic efficiency is **0.96** for all ratios \*Nel montaggio P la flangia può superare l'ingombro massimo dei piedi. Eventualmente utilizzare la flangia B14  
\* In the P mounting the B5 motor flange can exceed the foot maximum dimensions. Possibly use the flange B14

- Motor Flanges Available / Flange Motore Disponibili
- B) Supplied with Reduction Bushing / Fornito con Bussola di Riduzione
- B) Available on Request without reduction bushing / Disponibile a Richiesta senza Bussola di Riduzione
- C) Motor Flange Holes Position / Posizione Fori Flangia Motore







**EN** Unit **452A** is supplied with synthetic oil for lifetime lubrication, no maintenance is necessary. See table 1 for lubrication and recommended quantity. In table 2 please see possible radial loads and axial loads on the gearbox.

**I** Il riduttore **452A** viene fornito completo di olio sintetico per la lubrificazione permanente e non necessita di alcuna manutenzione. Vedi tab.1 per oli e quantità consigliati. In tab.2 sono presenti i carichi radiali e assiali applicabili al riduttore.

**D** Das Getriebe **452A** ist mit synthetischem Öl gefüllt und ist lebensdauergeschmiert. In Tabelle 1 ist die Schmiermenge und das empfohlene Schmiermittel angegeben. In Tabelle 2 sind die zulässigen Radial- und Axialbelastungen des Getriebes aufgeführt.

**F** Le réducteur **452A** est fourni complet avec de l'huile synthétique pour la lubrification permanente et ne nécessite aucun entretien. Voir tableau 1 concernant les huiles et les quantités conseillées. Les charges radiales et axiales applicables au réducteur sont précisées dans le tableau 2.

**E** El reductor tamaño **452A** se suministra, lubricado de por vida con aceite sintético y no requieren mantenimiento alguna. Ver tabla 1, para cantidades y aceites recomendados. En la tabla 2, se encuentran las cargas radiales y axiales admitidas por el reductor.

Standard supplied	For these mounting position specify in the order or add oil Per queste posizioni specificare in fase d'ordine o aggiungere olio					
						
B3	B6	B7	B8	V5	V6	V8
0.31 LT	0.31 LT	0.31 LT	0.31 LT	0.31 LT	0.31 LT	Ask
AGIP Telium VSF 320			SHELL Omala S4 WE 320			

For all details on lubrication and plugs check our website **tab. 1**  
Per maggiori dettagli su lubrificazione e tappi olio vedi il nostro sito web

### RADIAL AND AXIAL LOADS

**Output shaft / Albero di uscita**

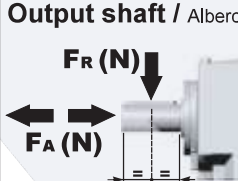

$F_R$  (N)  
 $F_A$  (N)

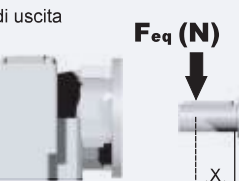

$F_{eq}$  (N)  
 $F_{eq} = F_R \cdot \frac{51}{X+21}$

$n_2$	FA	FR	$n_2$	FA	FR	$n_2$	FA	FR
300	415	2070	140	540	2700	70	700	3510
250	430	2160	120	560	2790	40	810	4050
200	470	2340	85	630	3150	15	900	4500

**Input shaft / Albero in entrata**



$F_R$  (N)  
 $F_A$  (N)

$n_1$	FA	FR
1400	400	2000
900	440	2200
500	440	2200

**tab. 2**

**P452A B1...** With feet  
Con piedini

Gearbox weight  
peso riduttore With flange **8.7 kg**  
With feet **8.9 Kg**

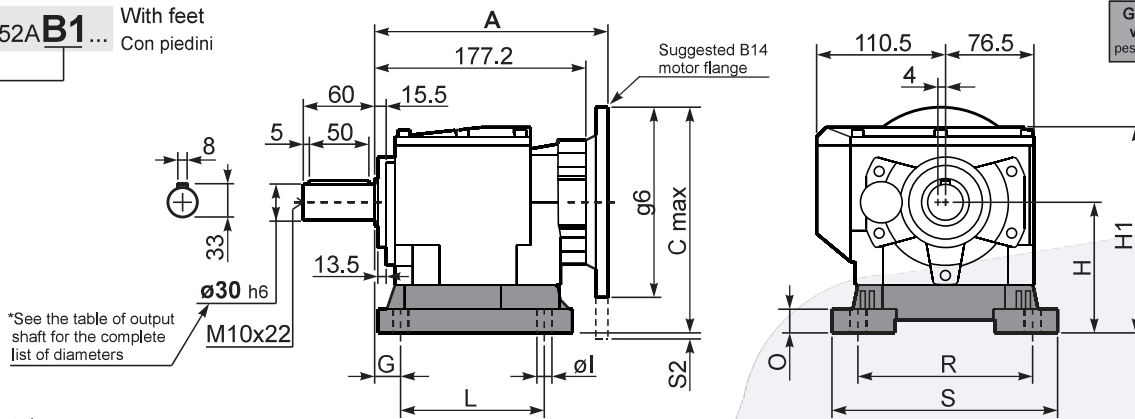

Feet / piedini

Feet Code	Market reference	G	H	R	L	S	H1	O	Øl	S2 only with motor flange	B5 max. Flange	kit code
<b>B3</b>	312/3	18	110	160	130	190	173	20	11	15 100/112B5 40 132B5	-	KC50.9.024
<b>B4</b>	30/35	20	130	180	149.5	216	193	18	14	20 132B5	-	KC60.9.024
<b>S4</b>	47-57	30	115	135	165	170	178	24	13.5	-	80/90B5	KC50.9.022
<b>H3</b>	023-233	30	130	135	135	185	193	25	14	20 132B5	-	KC50.9.025
<b>M2</b>	52/3	30	110	135-150	100	190	173	18	11	15 100/112B5 40 132B5	-	KC50.9.023
<b>L6</b>	06	19	125	160	106	205	188	8	14	25 132B5	-	KC50.9.026LM
<b>E2</b>	2202/3	13	100	135	192	164	163	6	14	-	71B5	KC50.9.027LM

Other feet are available, please contact Alpathek for information.

A see on page bottom

Most popular types  
Tipi più diffusi

**P452A-F...** Output flanges  
flange di uscita

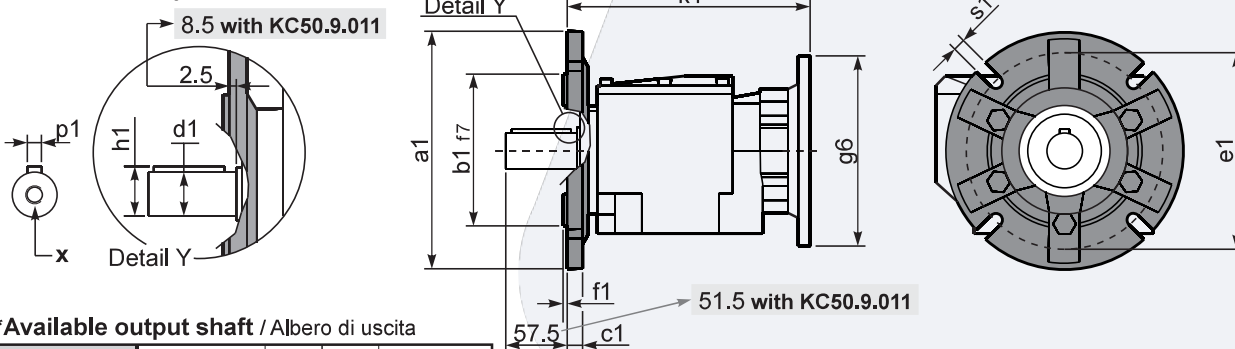

\*Available output shaft / Albero di uscita

	Shaft - d1	p1	h1	x
Standard	Ø 30x60	8	33	M10x22
On request A richiesta	Ø 24x50	8	27	M8x19
	Ø 25x50	8	28	M8x19
	Ø 28x60	8	31	M8x19
	Ø 35x60	10	38	M10x22

Available output flanges / flange di uscita

a1 Ø	b1	c1	e1	f1	s1	kit code
160	110	14	130	3.5	11	KC50.9.011
200	130	13	165	3.5	11	KC50.9.012
250	180	15.5	215	4	14	KC50.9.013

With flange and feet only on request. Ask for compatibility

**P452A-N...** Basic gearbox  
Riduttore base

**R452A-N...** Input Shaft  
Albero in entrata

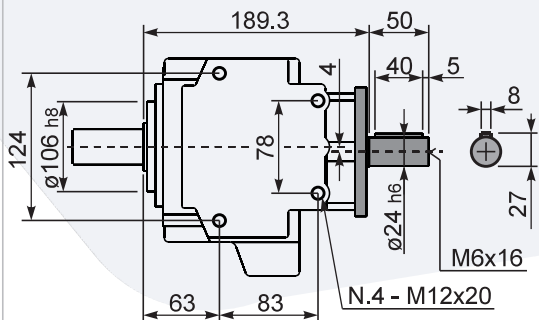
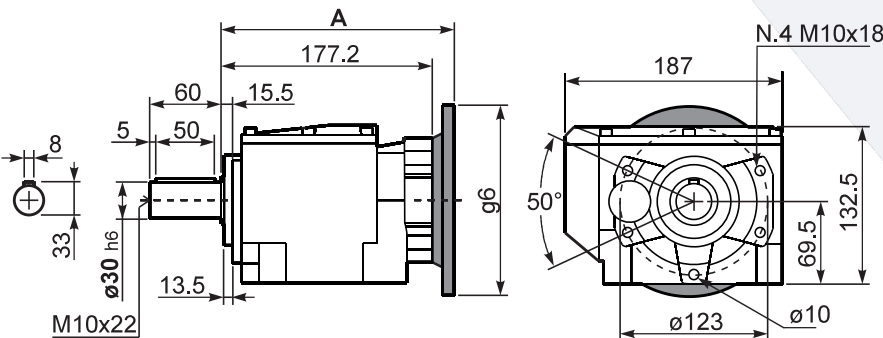

B5 Motor Flanges	A	C <sub>max</sub>	g6	k1	kit code	k1 with KC50.9.011	B14 Motor Flanges	A	C <sub>max</sub>	g6	k1	kit code	k1 with KC50.9.011
71 B5	195.7	222	160	198.2	K023.4.041	204.2	80 B14	197.7	202	120	200.2	K085.4.046	206.2
80/90 B5	197.7	242	200	200.2	K023.4.042	206.2	90 B14	197.7	212	140	200.2	K085.4.045	206.2
100/112 B5	206.7	267	250	209.2	K023.4.043	215.2	100/112 B14	206.7	222	160	209.2	K085.4.047	215.2
132 B5	224.7	292	300	227.2	KC50.4.043	233.2	132 B14	224.7	242	200	227.2	KC50.4.041	233.2