



▪ **QUICK SELECTION / Selezione veloce**

input speed (n_1) = 1400 min⁻¹

| Output Speed n_2 [min ⁻¹] | Ratio i | Motor power P_{1M} [kW] | Output torque M_{2M} [Nm] | Service factor f.s. | Nominal power P_{1R} [kW] | Nominal torque M_{2R} [Nm] | Available B5 motor flanges | | B14 motor flanges | | | | Output Shaft  | Ratios code  | | |
|---|--------------|---------------------------------|-----------------------------------|------------------------|-----------------------------------|------------------------------------|----------------------------|-----|----------------------|---|---|---|---|--|----|---|
| | | | | | | | -H | -I | - | - | - | - | | | - | - |
| | | | | | | | 160 | 180 | - | - | - | - | | | - | - |
| 528 | 2.65 | 22 | 374 | 1.7 | 36.7 | 650 | | | not available | | | | 2361 | standard | 01 | |
| 409 | 3.42 | 22 | 483 | 1.6 | 32.8 | 750 | | | | | | | 1965 | ø50 | 02 | |
| 304 | 4.60 | 22 | 649 | 1.5 | 30.9 | 950 | | | | | | | 1569 | | 03 | |
| 256 | 5.46 | 22 | 771 | 1.3 | 27.4 | 1000 | | | | | | | 1371 | ø55 | 04 | |
| 211 | 6.64 | 22 | 937 | 1.3 | 26.5 | 1175 | | | | | | | 1173 | On request | 05 | |

The dynamic efficiency is **0.98** for all ratios

A) Motor Flanges Available
Flange Motore Disponibili

B) Supplied with Reduction Bushing
Fornito con Bussola di Riduzione

B) Available on Request without reduction bushing
Disponibile a Richiesta senza Bussola di Riduzione

C) Motor Flange Holes Position
Posizione Fori Flangia Motore







EN Unit H81C is supplied without lubricant and equipped with a breather, level and drain plugs. User can add mineral oil keeping existing plugs. Should the user wish to fill it with synthetic oil, it is recommended to replace the existing plugs with a closed plug. See table 1 for lubrication and recommended quantity. In table 2 please see possible radial loads and axial loads on the gearbox.

I Il riduttore tipo H81C è fornito privo di lubrificazione con tappi di sfiato, livello e scarico olio. L'utente può immettere olio minerale mantenendo i tappi esistenti. Se immetterà olio sintetico, dovrà sostituire i tappi esistenti con altri tipo chiuso. Tab.1 per oli e quantità consigliati. Tab.2 carichi radiali e assiali applicabili al riduttore.

D Das Getriebe der Baugröße H81C wird ohne Schmiermittel geliefert. Es ist jedoch mit Einfüllschraube, Überdruckventil und Ablassschraube ausgerüstet. Das benötigte mineralische Öl kann über die Einfüllschraube eingefüllt werden. Sollte synthetisches Öl bevorzugt werden, so ist sind das eingebaute Überdruckventil durch eine geschlossenen Schraube zu ersetzen. In Tabelle 1 ist die Schmiermenge und das empfohlene Schmiermittel angegeben. In Tabelle 2 sind die zulässigen Radial - und Axialbelastungen des Getriebes aufgeführt.

F Le réducteur de type H81C est fourni sans lubrification et avec un bouchon de remplissage, de niveau et d'évacuation de l'huile. L'utilisateur peut y verser de l'huile minérale en conservant les bouchons existants. S'il y versera de l'huile synthétique, il devra substituer les bouchons existants avec d'autres bouchons de type fermé. Voir tableau 1 concernant les huiles et les quantités conseillées. Voir tableau 2 concernant les charges radiales et axiales applicables au réducteur

E El reductor tamaño H81C se suministra sin lubricante, provisto de tapones de respiración, nivel y descarga de aceite. El usuario puede utilizar aceite mineral, manteniendo los tapones existentes. Si prefiere utilizar aceite sintético deberá sustituir los tapones existentes por tapones ciegos. La prerreducción se suministra con tapones ciegos, lubricado de por vida con aceite sintético. Ver tabla 1, para cantidades y aceites recomendados. En la tabla 2, se encuentran las cargas radiales y axiales admitidas por el reductor.

| | | | | | | |
|---|--|---|---|---|---|---|
|  |  |  |  |  |  |  |
| B3 | B6 | B7 | B8 | V5 | V6 | V8 |
| 5.70 LT | 7.00 LT | 7.90 LT | 5.70 LT | 10.20 LT | 5.60 LT | Ask |
| AGIP Blasias 460 | | | | | | |

For all details on lubrication and plugs check our website **tab. 1**
Per maggiori dettagli su lubrificazione e tappi olio vedi il nostro sito web

RADIAL AND AXIAL LOADS

Output shaft
Albero di uscita

$F_{eq} = F_R \cdot \frac{227,5}{X+177,5}$

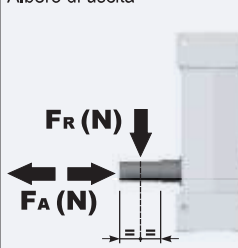

F_R (N)
 F_A (N)

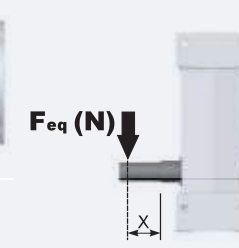

F_{eq} (N)

| n_2 | FA | FR | n_2 | FA | FR | n_2 | FA | FR |
|-------|------|------|-------|------|------|-------|------|-------|
| 300 | 920 | 4600 | 140 | 1120 | 5600 | 70 | 1400 | 7000 |
| 250 | 1000 | 5000 | 120 | 1140 | 5700 | 40 | 1800 | 9000 |
| 200 | 1060 | 5300 | 85 | 1300 | 6500 | 15 | 2400 | 12000 |

On request reinforced bearings to increase loads.
A richiesta cuscinetti rinforzati per aumentare i carichi.

tab. 2

PH81C... Basic gearbox
Riduttore base

Gearbox weight
peso riduttore **89.0 kg**

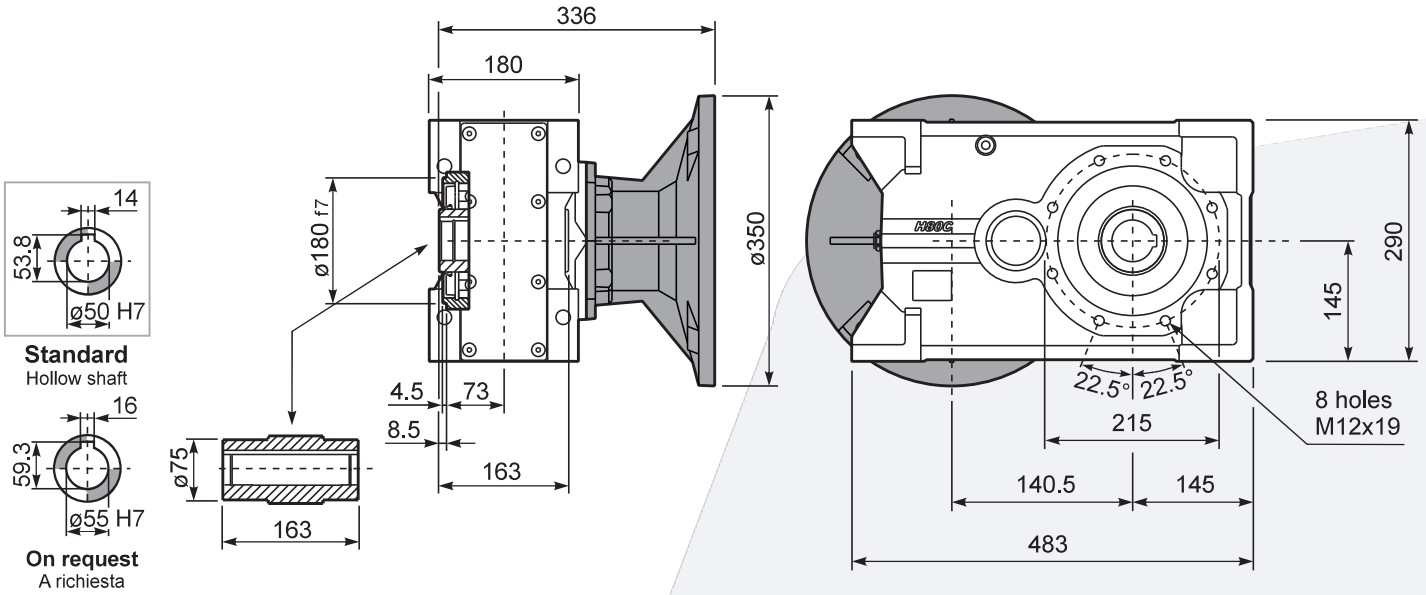

PH81C...-F Output flange
Flangia uscita

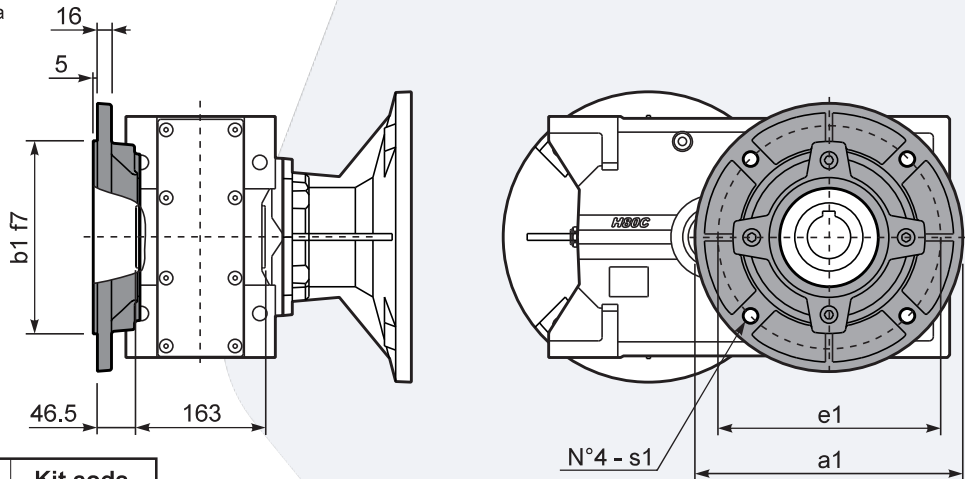

Available output flanges
Flange di uscita

| a1 ø | b1 | e1 | s1 | Kit code |
|------|-----|-----|----|------------|
| 300 | 230 | 265 | 14 | KF80.9.011 |
| 350 | 250 | 300 | 18 | KF80.9.012 |
| 400 | 300 | 350 | 18 | KF80.9.013 |

PH81C...-N Feet
Piedini

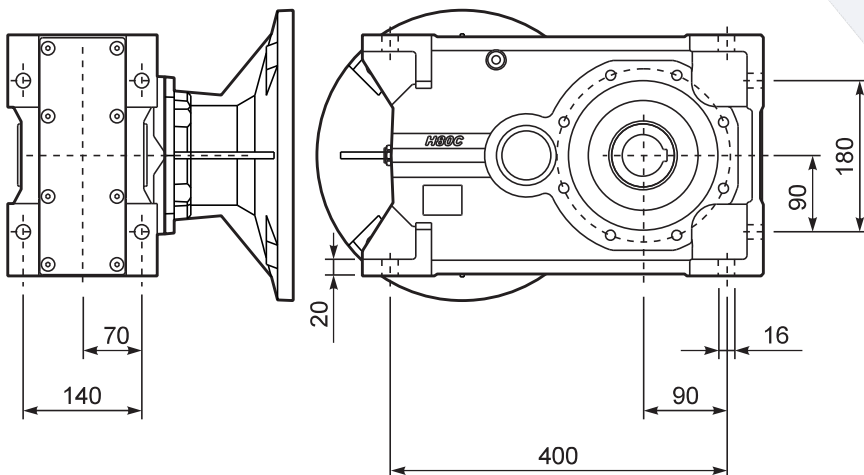

PH81C A... Single output shaft
Albero uscita semplice

Kit. Cod KF80.5.028

